

Quality Solution For All Growers .....



# Roller Spray Unit

From *K W Automation*



## MEETING GROWERS NEEDS

Fruit is transported through the spray tunnel on PVC rollers.

Rollers automatically turn the fruit while in the spray tunnel allowing the spray nozzles total coverage of all pieces of fruit.

Variable speed settings allow the Spray Unit to meet the stringent D.P.I. standards being rigidly administered in Queensland since the outbreak of the Papaya Fruit Fly.

A drip tray is ideally situated to collect excess chemical solution.

In conjunction with our optional 100 ltr spray tank and optional extraction fan the spray unit gives formidable performance.

- ▶ **Minimal** maintenance with stainless steel conveyor chain.
- ▶ **Compatible** adjustable legs allow continuity of fruit.
- ▶ **Longevity** stainless steel bearings ensure a longer life.
- ▶ **Durable** Powder Coated for extra protection.
- ▶ **Safety** totally enclosed to help contain overspray to a minimum.
- ▶ **Unique** use of variable speed geared motor for flexibility.
- ▶ **Spray Unit** meets stringent D.P.I. Standards.
- ▶ **Optional** 100 litre Spray storage tank and pump system to supply spray nozzles.
- ▶ **Optional** Extraction fan to remove unwanted fumes.



Manufactured By:

***K W Automation***

PO Box 121, Old Bowling Green Rd  
Palmwoods, Queensland 4555 Australia  
Int (61) - (07) 5445 9549 - Fax (07) 5445 0499  
Web Site: [www.kwautomation.com.au](http://www.kwautomation.com.au)

Roller Spray Unit	Specifications
Capacity Fruit/Min. (80% capac.)	120 Pieces *
Capacity Fruit/Hour (80% capac.)	7200 Pieces *
Capacity Tonne/Hour (80% capac.)	2.5 Tonne *
Capacity of Gearing Motor	.18 kW (1/4 HP)
Power Supply Req'd	240V or 415V
Length	1.530 Metres
Width	.930 Metres
Height	1.500 Metres

\* Based on average 350gram fruit at approx. 80 mm.

N.B. Optional - 100 Ltr Fibreglass Spray Storage Tank and Pump System to supply spray nozzles.

Optional - 76 Watt, 240 Volt, Extraction Fan (160 Diameter ) to remove unwanted fumes.

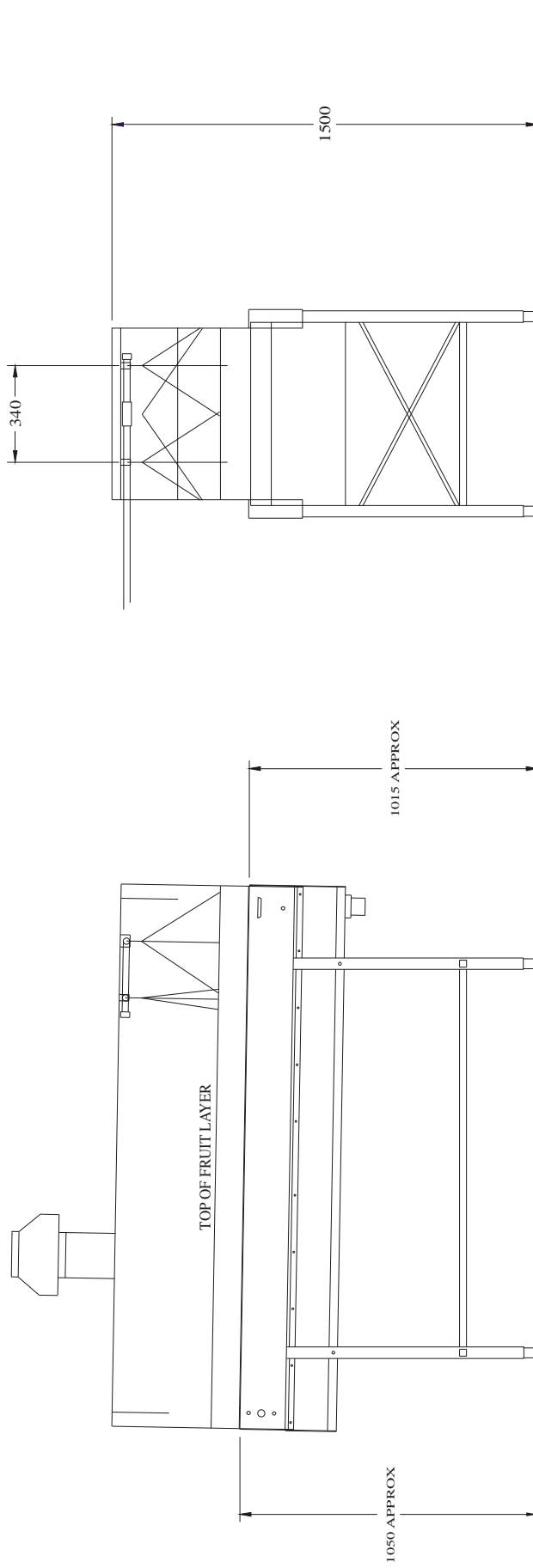
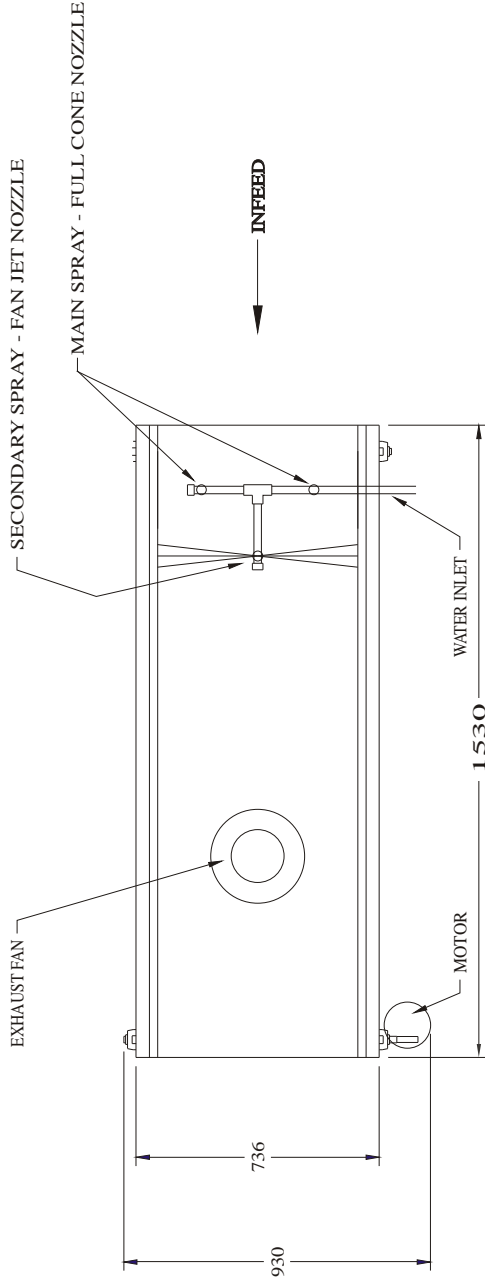

Please note all plans & specifications may change without further notice.