

Quality Solution For All Growers . . . .



# Roller Creepfeeder

From *K W Automation*



- ▶ **Durable** - powdercoated for extra protection.
- ▶ **Longevity** - low maintenance, all sealed bearings.
- ▶ **Variety** - of Fruit & Vegetables catered for with different size Creepfeeders available.
- ▶ **Versatile** - Variable Speed Drive allows to increase/decrease flow of fruit into fruit processing line.
- ▶ **Roller Creepfeeder** lined with marine grade carpet.
- ▶ **Optional** -padded with foam and vinyl for soft handling of fruit.

## Meeting Growers Needs

**KW Automation** have designed and manufactured their Creepfeeders with the ability to feed small, soft sensitive fruit in both small and large volumes.

Different sizes of Hopper on the Creepfeeders are available at time of purchase.

Small Hoppers designed for small fruit such as Cherry Tomatoes allow for easier, more gentle, handling of fruit.

Creepfeeders with large Hoppers allow the processing of large volumes of fruit while at the same time retaining their gentle handling ability.

### Manufactured By:



***K W Automation***

PO Box 121, Old Bowling Green Rd  
Palmwoods, Queensland 4555 Australia

Int (61) - (07) 5445 9549 - Fax (07) 5445 0499  
[www.kwautomation.com.au](http://www.kwautomation.com.au) OR [info@kwautomation.com.au](mailto:info@kwautomation.com.au)

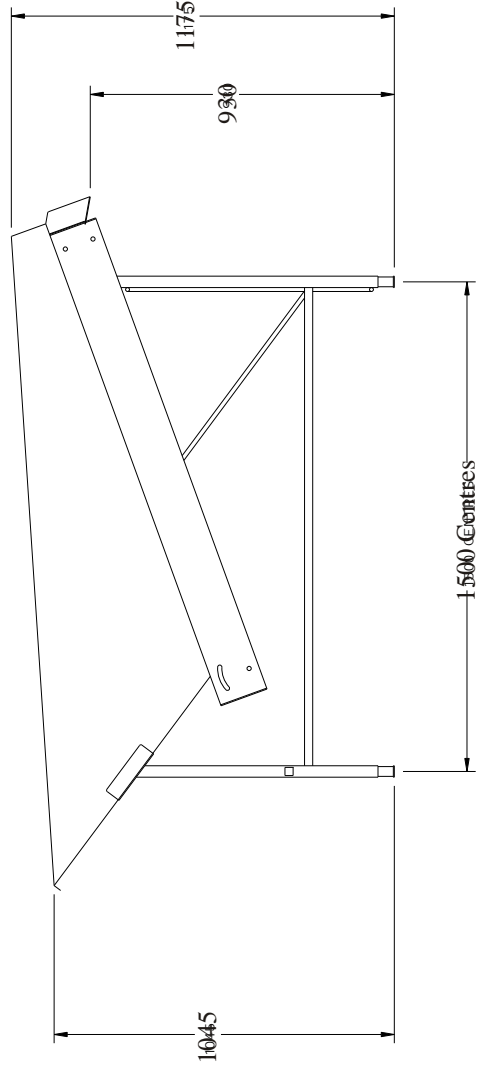
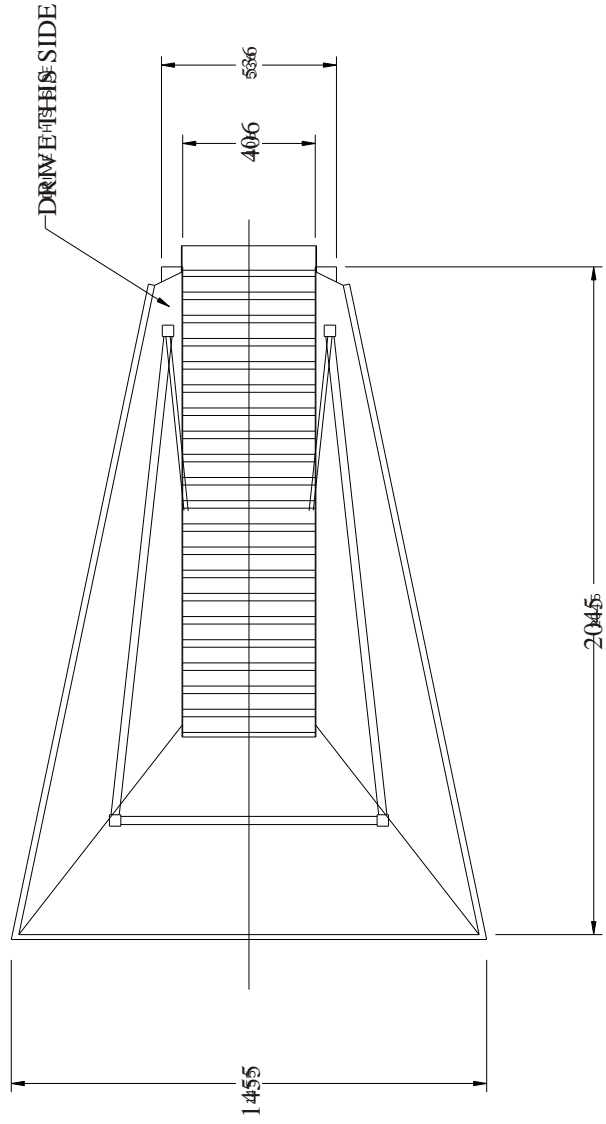

Heights are adjustable

Please note all plans & specifications may change without further notice.

CF 120 Creepfeeder	Specifications
Capacity of Geared Motor	0.18kW (1/4 H.P)
Power Supply Required	240V (single phase) or 415V
Length	2.200 Metres
Width	1.400 Metres
Height	1.050 Metres
Volume of Fruit/Hour*	1.5 Tonne

\*Based on 350 gram fruit

