

Quality Solution For All Growers

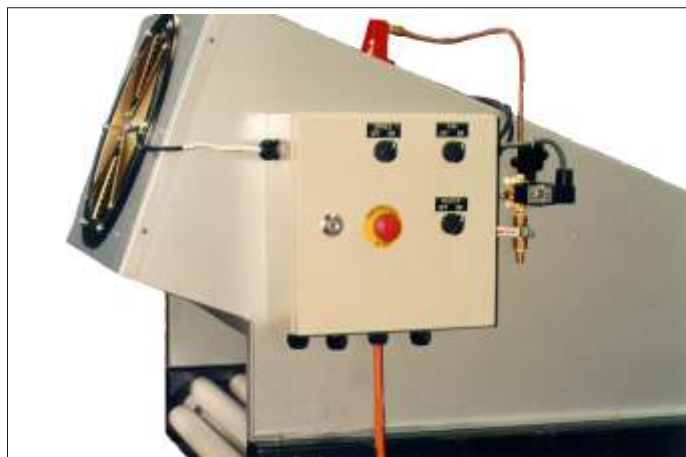

Drying Tunnel

From *KW Automation*



- ▶ **Regulated** temperature with easily adjusted gas pressure.
- ▶ **Compatible** height adjustable legs allow smooth continuity of fruit line.
- ▶ **Easily** started gas system with automatic electronic ignition.
- ▶ **Durable** Powder Coated for extra protection.
- ▶ **Safety** with solenoid " flame out " device.
- ▶ **Controlled** flow of fruit available via variable speed roller conveyor.

Fruit is transported through the **Drying Tunnel** on PVC rollers.

The rollers automatically turn the fruit while in the Drying Tunnel allowing the heated air to totally engulf all pieces of fruit.

The variable speed roller conveyor allows the flow of fruit to proceed at a compatible pace to other machines on the fruit processing line.

On a single drying tunnel one fan forces air into the tunnel over a LP gas burner. In a double tunnel 2 fans and 2 burners feature.

Burners are fired up with an easy start switch and maximum oven temperatures maybe set from 35 to 45 C.

Cleaning and maintenance has been made easy with the hinged lower cover tray.



Manufactured By:

KW Automation

PO Box 121, Old Bowling Green Rd
Palmwoods, Queensland 4555 Australia

Int (617) - (07) 5445 9549 - Fax (07) 5445 0499

www.kwautomation.com.au OR info@kwautomation.com.au

" 4.0 METRE DOUBLE DRYING TUNNEL "

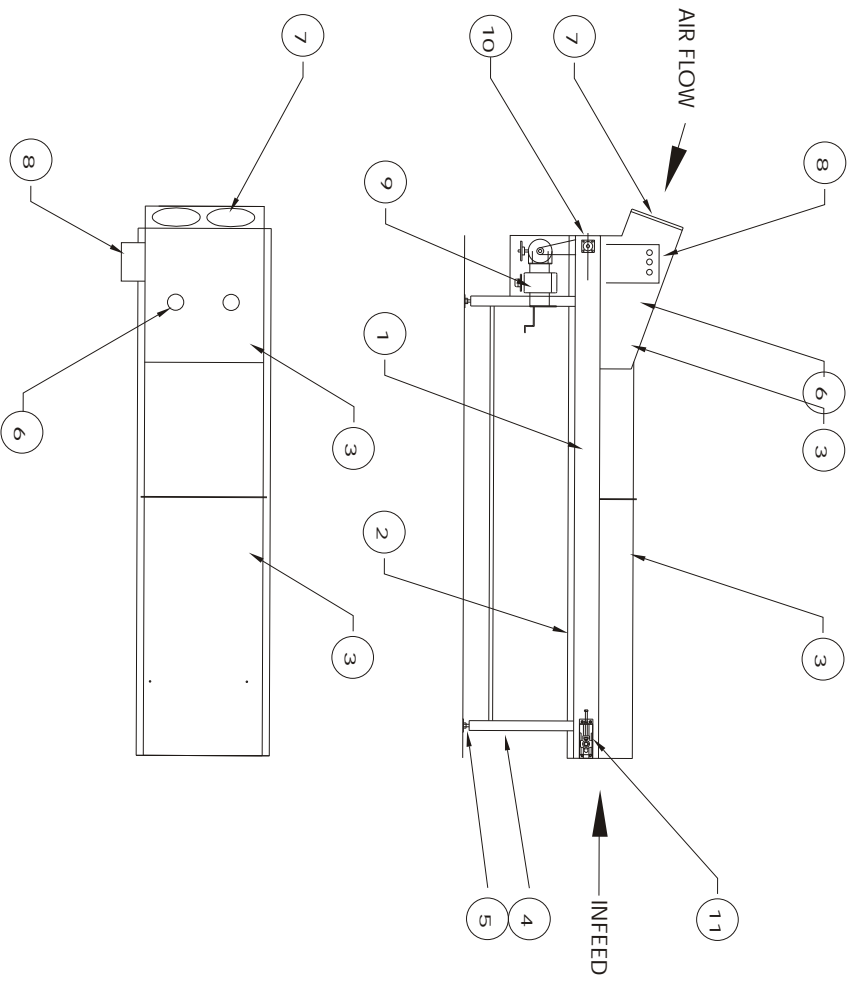

11.	TAKE-UP BEARING	2
10.	FIXED BEARING	2
9.	ELECTRIC MOTOR	1
8.	CONTROL PANEL	1
7.	FORCED DRAFT FAN	2
6.	LPG HEATER	2
5.	ADJUSTABLE LEG	4
4.	SUB-FRAME	1
3.	TUNNEL COVER	2
2.	BOTTOM CLOSURE	1
1.	CONVEYOR FRAME	1
ITEM	DESCRIPTION	QTY

N.B. For warmer and dryer climates tunnels may be purchased without LP Gas burners.
Tunnels' length may also be customised to meet growers needs.

	Single Tunnel	Double Tunnel
Length (metres)	3.35 or 4.0	4.0
Width (metres)	.750	.900
Height (metres)	1.700	1.700
No. of Fans	1	2
No. of Gas Burners	1	2
Capacity of Geared Motor	.18kW (1/4 HP)	.18kW (1/4 HP)
Power Supply Required	240 or 415V	240 or 415V
LP Gas Operating Pressure	50-100KPA	50-100KPA
Width of PVC Rollers	600mm	900mm
Pieces Fruit Processed/Hour*	7,500	11,000

* Based on 80mm diameter fruit.

Please note all plans & specifications may change without further notice.